

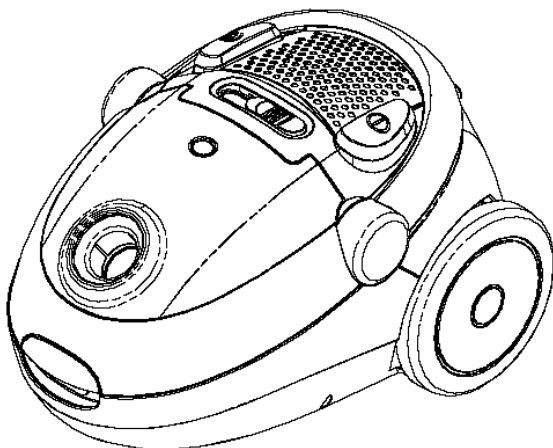

designed for life

pet
master

**VACUUM CLEANER
SC11041**



USER INSTRUCTIONS



GUARANTEE

This product is guaranteed for 2 years from the date of original purchase. If any defect arises due to faulty materials or workmanship, the unit will, either be repaired, replaced or refunded at our discretion.

The following conditions apply:

- ❑ The product must be returned to the retailer with original proof of purchase.
- ❑ The product must be installed and used in accordance with the instructions contained in this user instruction guide.
- ❑ It must be used only for domestic purposes.
- ❑ It does not cover wear and tear, damage, misuse or consumable parts.
- ❑ The supplier has no responsibility for incidental or consequential loss or damage.
- ❑ Valid in the UK & Eire only.
- ❑ Valid only if purchased from the SDHS Group

Technical Specification:

Power supply:	220V-240V AC. 50Hz
Power Consumption:	1800 W Max
Model number:	SC11041
Protection:	Class II



SDHS Group
L70 1AB
Box MPRC8

Swan Vacuum Helpline. Please Call 01733 404703
Swan Vacuum Spare Parts. Please Call 01733 404709
Calling from outside the UK Please Call - 00 44 1733 404703

IMPORTANT SAFETY INSTRUCTIONS

READ THIS SECTION TO BE AWARE OF THE RISK OF PERSONAL INJURY, DAMAGE TO PROPERTY, ELECTRIC SHOCK & FIRE.

1. This appliance is not intended for use by persons (including children) with reduced physical, sensory or mental capabilities, or lack of experience and knowledge, unless they have been given supervision or instruction concerning use of the appliances by a person responsible for their safety.
2. Children should be supervised to ensure they do not play with the appliance.
3. Never vacuum wet surfaces, pick up wet objects or use in wet conditions.
4. Always disconnect the vacuum from the electrical supply before attempting any servicing or maintenance. Never leave the vacuum unattended when plugged in.
5. Do not vacuum anything that is burning or smoking, such as cigarettes matches, or hot ashes.
6. Do not use the vacuum cleaner to pick-up large objects that could damage or cause a blockage.
7. Do not use the vacuum to pick up builders rubble, sand, plaster dust etc.
8. This vacuum cleaner is for domestic use only. Industrial or commercial use invalidates the warranty.
9. Do not use without a dust bag/bin and filter in place.
10. Use extra care when cleaning on stairs.
11. Keep hair, loose clothing, fingers and all parts of the body away from openings and moving parts.

Safety Alerts:

1. To reduce the risk of electric shock, do not use outdoors or on wet surfaces.
2. Use only as described in this manual.
3. Do not use with a damaged cord or plug.
4. Do not run the vacuum cleaner over the cord. Keep the cord away from heated surfaces.
5. Do not unplug by pulling on the cord. To unplug, grasp the plug, not the cord.
6. Do not handle the plug or the vacuum cleaner with wet hands.
7. Turn off all controls before unplugging.

This vacuum cleaner is equipped with a plug and a cable, which rolls up automatically. If either becomes damaged, a qualified service agent must repair both the plug and cable.

Electrical Safety

Before switching on, make sure that the voltage of your electricity supply is the same as that indicated on the rating plate. This product is designed to operate on 220 – 240V AC, 50Hz. Connection to any other power source may damage the unit.

This product may be fitted with a non – rewirable plug. If it is necessary to change the fuse in the plug, the fuse cover must be refitted. If the fuse cover becomes lost or damaged, the plug must not be used until a suitable replacement obtained.

If the plug has to be changed because it is not suitable for your socket, or becomes damaged in any way, it should be cut off and an appropriate plug fitted following the wiring instructions below. This should be carried out by a qualified electrician. The plug removed must be disposed of safely, as insertion into a 13 Amp socket is likely to cause an electrical hazard.

IMPORTANT – THIS IS A CLASS II APPLIANCE AND DOES NOT REQUIRE AN EARTH CONNECTION.

Wiring Instructions

The wires in this mains lead are colored in accordance with the following code:

Blue = Neutral

Brown = Live

As the colours of the wires in the mains lead of this appliance may not correspond with the coloured markings identifying the terminals in your plug, proceed as follows (refer to the plug wiring diagram).

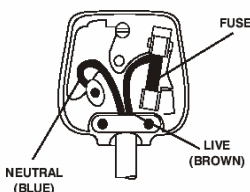

- The wire which is coloured **BLUE** must be connected to the terminal which is marked with the letter **N** or coloured Black.
- The wire which is coloured **BROWN** must be connected to the terminal which is marked with the letter **L** or coloured Red.

If a 13Amp (BS1363) plug is used, a 13Amp (BS1362) fuse must be fitted, or if any other type of plug is used, a 13Amp fuse must be fitted, either in the plug or adaptor, or on the Distribution Board.

Description:

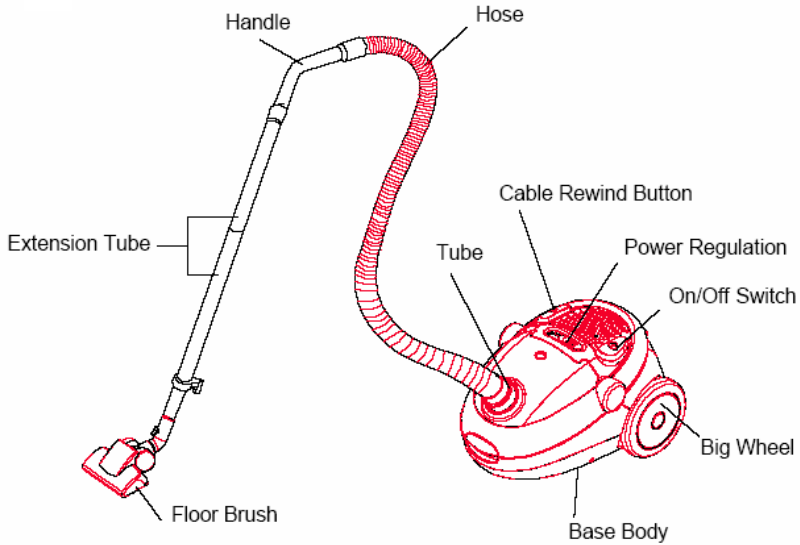

Turbo brush:



The turbo brush is a rotating brush driven by the suction of the vacuum cleaner.

Brushing agitates the surface and releases more dirt than suction power alone.

The brush action is also more effective in picking up pet hairs.

Swan Vacuum Helpline. Please Call 01733 404703
Swan Vacuum Spare Parts. Please Call 01733 404709

ASSEMBLY INSTRUCTION:

Always remove the plug from the power socket before fitting or removing accessories!

1. Fitting and removing the flexible hose.

Fitting:

Insert the flexible hose into the suction hole. Push until it clicks and locks into position.

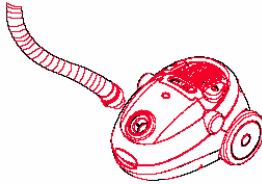

Removing:

Press the button to release and pull the hose from the suction inlet.

2. Fitting the extension tubes, floor head and accessories.

a. Fit the extension tube to the hose nozzle.

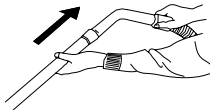

b. Fit the floor brush or turbo brush to the chrome telescopic tube.

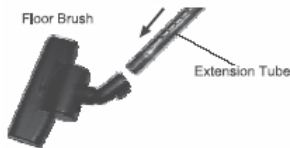

c. The chrome telescopic tube can be extended by pushing the release button and pulling the tube.



d. Floor head - ideal for the daily cleaning on carpets and hard floors.

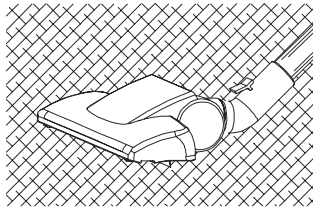
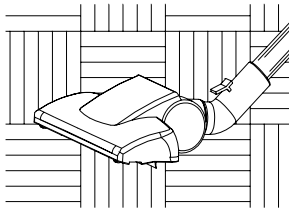

Cleans on the carpet

For use on hard floors ensure the floor head bristles are extended.

e. Crevice tool - for radiators, corners, baseboards and between cushions.

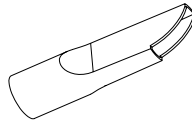

f. Soft brush and upholstery attachment – ideal for fabrics, picture frames and cleaning the sofa.

To use the upholstery tool slide the brush head off the attachment.

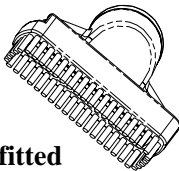

Brush head fitted

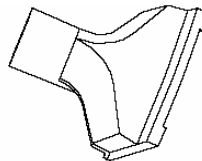

Brush head removed

Note: The crevice and soft brush attachments are stored at the rear of the vacuum.

INSTRUCTIONS FOR USE

1. Unwind a sufficient length of cable. A yellow mark on the power cable shows the ideal cable length. **Do not** extend the cable beyond the red mark.

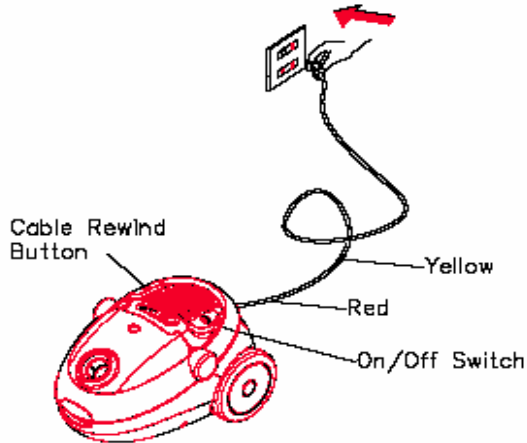

2. You should plug the appliance into a 220V-240V SUPPLY ONLY.

Before connecting to the power source, make sure the paper bag; filter and accessories are fitted correctly. **Do not operate without dust-bag or filters in place.

3. Press the ON/OFF power switch to start vacuuming.

4. The SC11041 vacuum has a sliding power regulator which allows easier suction control when vacuuming.

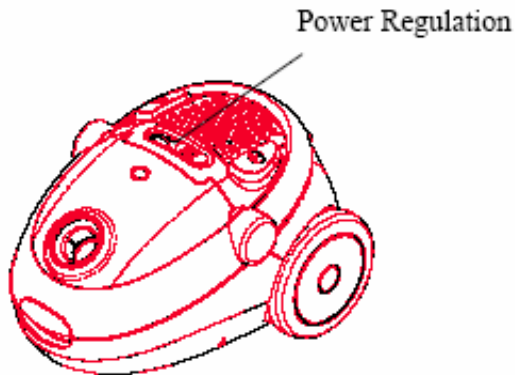

5. Thermal cut out:

This vacuum is fitted with a thermal cut out device, which protects the vacuum if the motor should overheat. If the cleaner suddenly stops, please check the following:

- a. Switch off the cleaner and unplug from the power supply.
- b. Check the cause of overheating; blocked hose, clogged filter, full dust-bag etc.
- c. Clear the blockage, clean / replace the filter or empty the dust-bag as necessary.
- d. Wait 30 – 60 minutes, the thermal device will reset automatically

Cord Rewind: to rewind the power cord, press the rewind button with one hand and guide the cord with the other hand to ensure that it doesn't whip causing damage.

Swan Vacuum Help-line Call 01733 404703
Swan Vacuum Spare Parts Call 01733 404709
Calling from outside the UK Please Call - 00 44 1733 404703

MAINTENANCE

1.Changing the dust bag

- Always operate the cleaner with dust bag installed.
- If you forget to attach the dust bag or attach it in the wrong manner, the dust cover may not close completely.

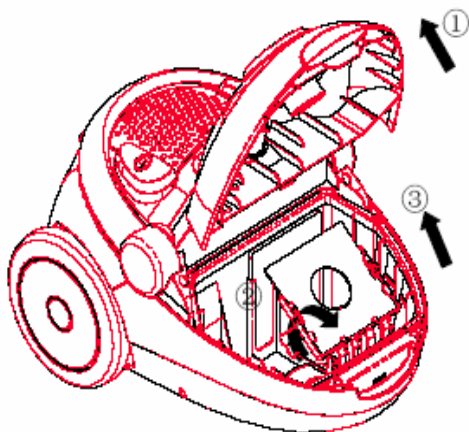

1. After removing the flexible tube, open the front cover .

2. Rotate the support of the bag to the correct position.

3. Remove the dust bag.

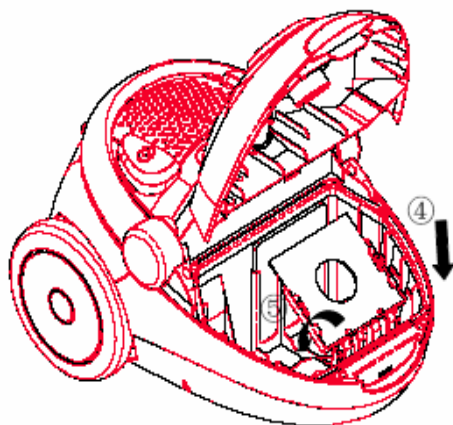

4. Replace the paper bag when it is full of dirt and put in a new one.

5. Close the cover by pushing down until it is locked.

2. Cleaning / Changing the Carbon inlet filter:

- The filter should be cleaned at least twice a year or when it becomes visibly solid. This filter can be washed clean in warm water.
- Always operate the cleaner with the filter installed, otherwise reduced suction or motor damage may occur.
- Disconnect from the electrical outlet before cleaning the filter.
- Do not use a washing machine to wash / rinse the filter.
- Do not use a hair drier to dry it.
- Allow 24 hrs to air dry before refitting the filter.

1. Remove the dust bag as described in the previous section.

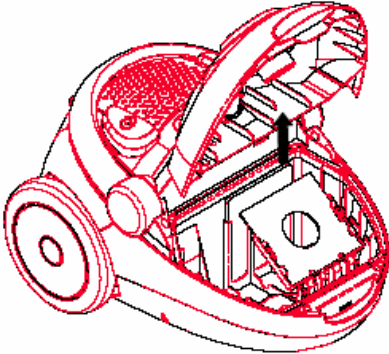

2. The filter is located behind the dust bag. Lift out the filter.
3. Either rinse or replace the filter. If you decide to rinse, wash in warm water and allow the filter to air dry completely before refitting.

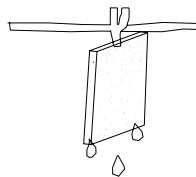
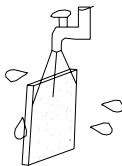

4. Refit the filter and bag ensuring the bag is correctly located.

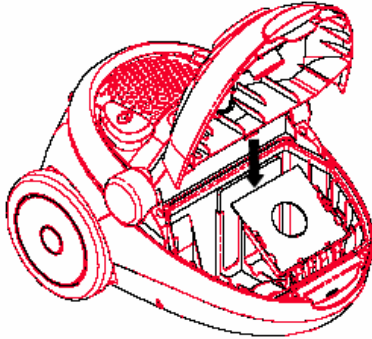

3. Cleaning / Changing the Hepa exhaust filter:

- Disconnect from the electrical outlet, before cleaning the filter.
- Always operate the cleaner with the filter installed.
- **Lightly brush the filter clean when it becomes it visibly solid. For optimum performance this filter should be replaced at least once a year.**
- **Do not wash / rinse this filter.**

1. Unclip the exhaust filter cover and lift out the filter.

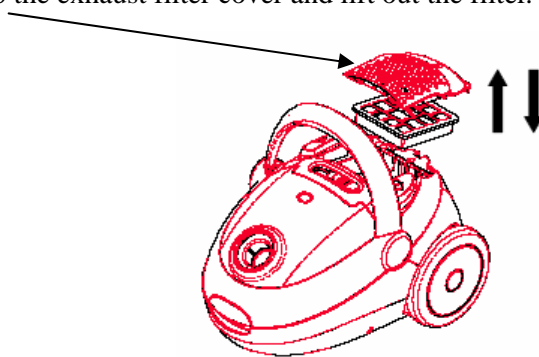

2. Lightly brush the filter clean or replace the filter. **For optimum performance, it is advised the Hepa filter is replaced once a year.**

3. Refit the exhaust filter and clip on the cover.

If your appliance should fail, please check the following:

- * Make sure the mains plug is correctly fitted in the socket.
- * Check the fuse in the plug.
- * Try another socket.
- * In case the thermal cut out has tripped, allow 30 – 60 minutes for the cutout device to reset. Please check for blockages in the hose, filters and dust-bag.

Service

- If the vacuum power cord has been damaged in any way, do not use the vacuum cleaner. The vacuum cleaner must be repaired by a qualified service agent.
- If you have any technical problems with your vacuum cleaner, please call the Swan helpline: 01733 404703.

SPARE PARTS LIST

SC11040 /01	Hose & Nozzle
SC11040 /02	Floor Head
SC11040 /03	Chrome telescopic tube
SC11040 /04	Crevice tool
SC11040 /05	Small Brush / Upholstery tool
SC11041 /06	Turbo brush
SC11041 /51	Filter Kit
SC11040 /52	10 Paper dust-bags

SWAN VACUUM HELP-LINE: PLEASE CALL 01733 404703

SWAN VACUUM SPARE PARTS: PLEASE CALL 01733 404709

Calling from outside the UK Please Call - 00 44 1733 404703

WASTE ELECTRICAL RECYCLING

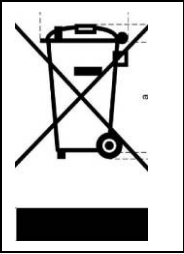

This symbol indicates that this product is classed as Electrical or Electronic Equipment and should not be disposed of with other household waste.

The Waste Electrical and Electronic Equipment (WEEE) Directive has been introduced across the European Union:

- to recycle waste electrical products using the best available recovery and recycling techniques in order to minimise the impact on the environment
- to treat any hazardous substances and
- to avoid increasing landfill.

WEEE product should be disposed of by handing it over at a designated collection point.

For more information about where you can drop off your waste product for recycling please contact your local authority.

